



MTK Series
DWDI, Forward Blades
Direct Driven
CENTRIFUGAL FAN





Designation of Products

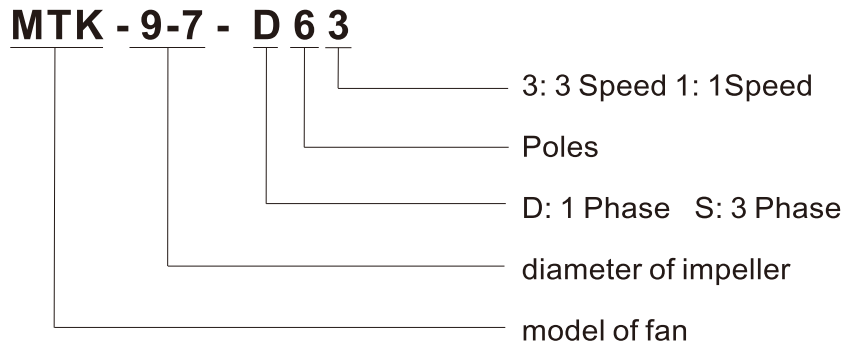

Technical specification

MTK series air condition fan adopts double suction forward curved impellers, belongs to metric and British system middle-low pressure forward air condition fan series.

Whist, energy-saving, little volume, convenient installation, can be used in workshop, plant, hotel, large market, building for ventilation, collocate using with Central air condition set, purify equipment, end of air conditioner etc.

Motor adopts direct driving, can reduce noise, to ensure steady long-term operating. The speed of single phase motor can be changed, so it can meet many different requirements of customers.

Impeller adopts forward curved multi-blades, balance precision is G4.0

All parts use galvanized steel as material, it's anticorrosive.

Prohibit to fully open inlet when operating, to avoid motor damage caused by overload.

It operated in environment with on inflammable, explosive, erosive air, solid grain contained below $100\text{mg}/\text{m}^3$, and air temperature is between $-10^\circ\text{C}\sim 40^\circ\text{C}$.

Performance of MTK Fans are not licensed by AMCA International.



MTK10-10-D63

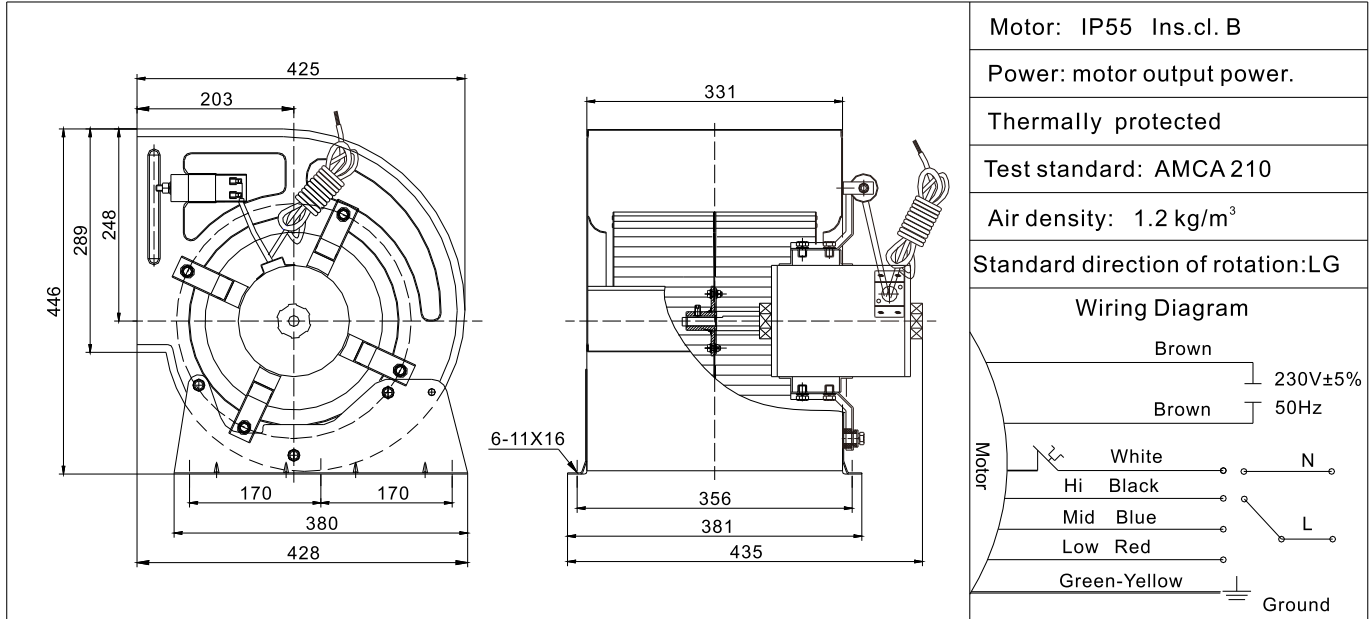

Motor: IP55 Ins.cl. B
 Power: motor output power.
 Thermally protected
 Test standard: AMCA 210
 Air density: 1.2 kg/m³
 Standard direction of rotation: LG

Wiring Diagram

Hi. speed	Speed	890 r/min	Power	450 W	Amp.	3.0 A	
Mid. speed	Speed	820 r/min	Power	330 W	Amp.	2.0 A	
Low speed	Speed	740 r/min	Power	250 W	Amp.	1.7 A	
Capacitor		16μF /450V	Voltage		230V±5% / 50Hz	Weight	20 kg

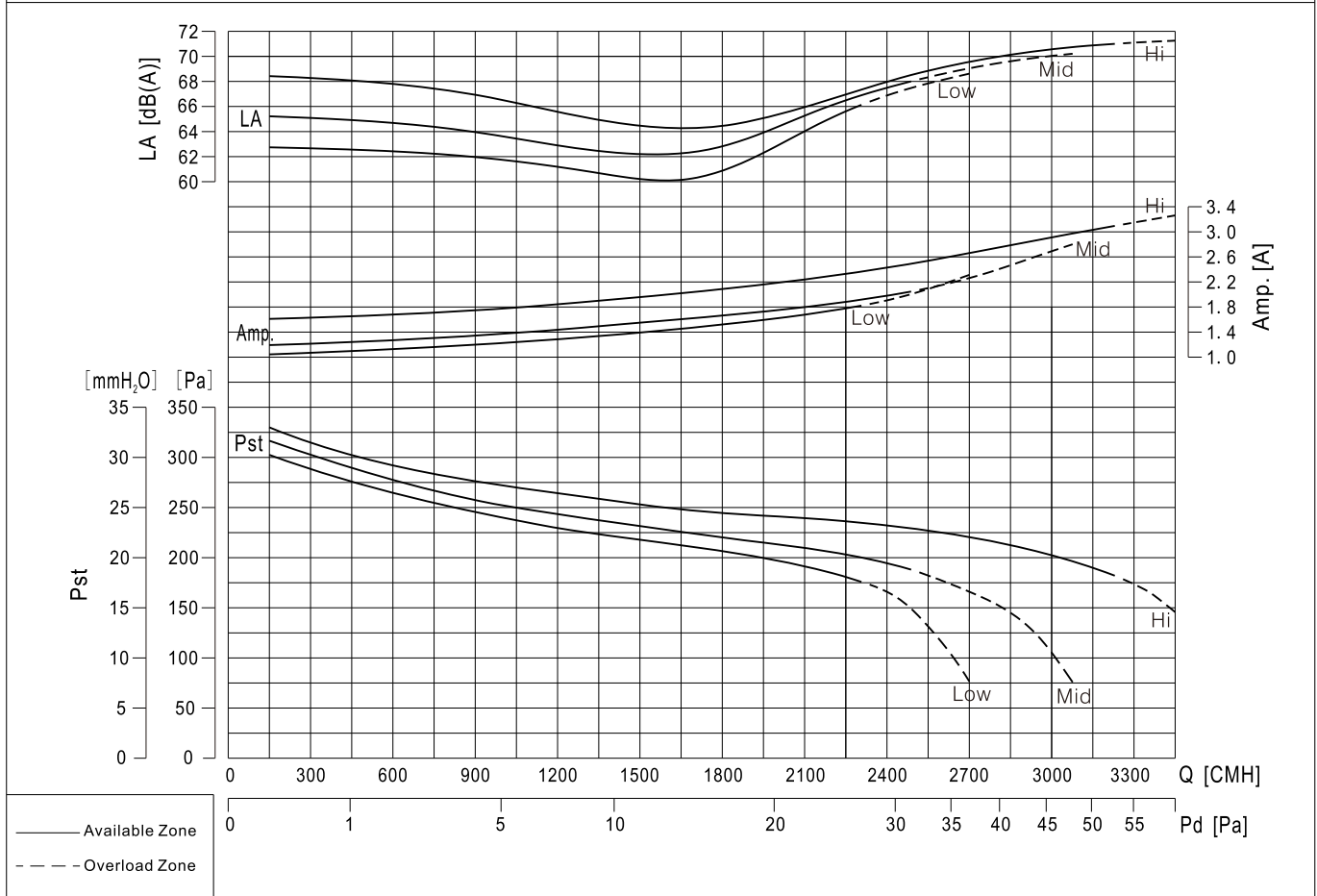

MTK Series